

Literature

LEAR – Literature Management

DDBSP - Dortmund Data Bank Software Package



DDBST Software & Separation Technology GmbH

Marie-Curie-Straße 10

D-26129 Oldenburg

Tel.: +49 (0) 441 361819 0

Fax: +49 (0) 441 361819 10

E-Mail: support@ddbst.com

Web: www.ddbst.com

Contents

Starting LEAR.....4

 The Tool Bar.....4

 The Menu Bar.....4

 The File Menu.....5

 New Library.....5

 Open.....5

 Close Library.....5

 Load Setnumbers.....5

 New Dataset.....5

 Import.....5

 Delete Library.....6

 Extras.....6

 Rebuild Index.....6

 Duplicate Search.....6

 Retrieve Keywords.....7

 Update Ref Files.....7

 External Links Settings.....7

 Exit.....7

 The Edit Menu.....7

 Global Options Page.....8

 Result Window Options Page.....9

 Import Options Page.....10

 Environment Options Page.....10

 The View Menu.....10

 The Help Menu.....11

Searching.....12

 Quick Search.....12

 Advanced Search.....13

 Search Fields.....15

 String Fields.....15

 Number Range Fields.....15

 Date Fields.....15

 Journal Field.....15

 Status.....15

 Links.....15

 Multiple Queries.....15

Search Results.....17

 Tool Bar.....17

 Menus.....18

 Results.....18

 Edit.....18

 Search.....18

 View.....18

 Options.....19

 Windows.....19

Grid Functions.....	19
Sorting.....	19
Column Moving.....	20
Context Menu.....	20
Journals.....	22
Stored Fields.....	22
Editing.....	22
Searching.....	23
Selecting Journals.....	23
Editing Single Sets.....	24
List of Fields.....	24
Tool Bar.....	27
Special Command Buttons.....	28
Font Selection.....	28
Displaying Externally Linked Files and Folders.....	29
Appendix.....	30
The Usage of Links.....	30
The Data Bank Structure.....	30
LEAR tagged format.....	31

Starting LEAR

LEAR is the literature management part of DDBSP.



A fresh installed LEAR only contains a single database. It's the “DDBST” database containing all references for the DDBST data banks.

The second database shown here is another “DDBST” database suffixed by a “/p”. This database contains all private references for customer-created data banks. Section *The File Menu* describes how to create a private literature database.

LEAR handles also other – non-DDBST user-specific databases – they must not have the name “DDBST”.

The status line

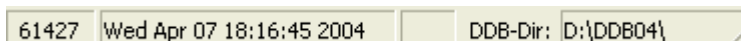

displays the number of available datasets, the data and time of the latest write access of the database under the mouse cursor. In addition always the folder of the Dortmund Data Bank is displayed.







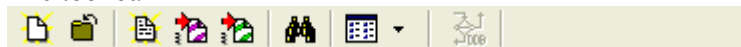

When the mouse cursor is over a database icon the full path to the database file is displayed as hint. This also true when the option “*Display Hints as Popup*” in the “*Global*” part of the options menu is turned off.

The Tool Bar

The tool bar



contains shortcuts to some functions.

-  Create a new and empty literature data bank (library)
-  Close a data bank
-  Append a new and empty data set to a selected library
-  Import a PCP tagged file (import of pure component properties files)
-  Import another LEAR data bank
-  Search in library or libraries
-  Change display mode of data bank list
-  Create a private library (only active if there is currently none)
-  Show About Dialog

The Menu Bar

File Edit View ?

The File Menu

New Library

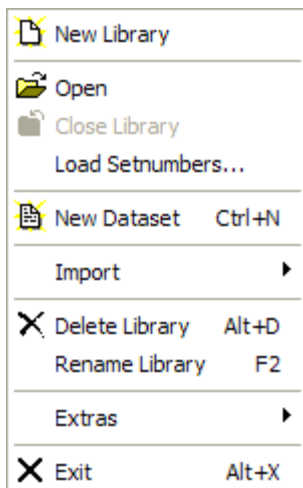

“*New Library*” creates a new personal literature database. If the “private DDB” literature database does not exist it can be created using the first option. The second option creates a user specific database which can't be associated with experimental data like VLE.

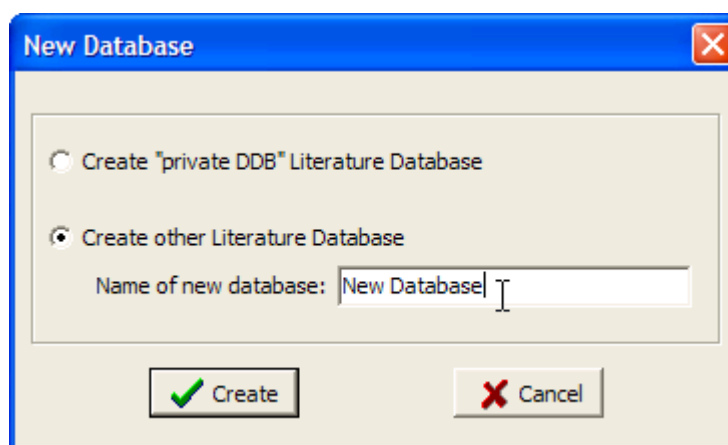

The database is always created in the “LITERAT” sub folder of the private DDB folder.



This location is indicated by the “/p” suffix.

Open

“*Open*” opens the currently selected data bank and displays the complete list of entries. The same happens when an icon is double-clicked.

Close Library

“*Close Library*” is closing the database file stream but does not close any open result list.

Load Setnumbers

“*Load Setnumbers...*” allows to load a file (STX format) that contains dataset numbers. These files can be created in LEAR – representing a search result – or in the main data bank retrieval program – containing all references of datasets in a query result.

New Dataset

“*New Dataset*” allows to enter a new dataset. This is described later in detail.

Import

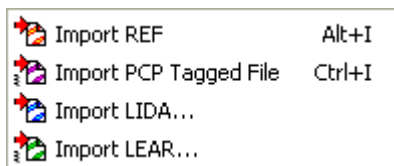

“*Import*” allows to add datasets from other files and formats.

The “REF” format is an old DDB format which has been superseded by LEAR, “PCP Tagged Files” are exchange files for pure component properties, “LIDA” is the predecessor of “LEAR” and now deprecated and “Import LEAR” allows to import other LEAR data banks.

Delete Library

“*Delete Library*” allows to remove the selected database files – only the main “DDBST” library cannot be removed. **A removed database can not be restored.**

Rename Library

“*Rename Library*” allows to change the name of a data bank. The standard DDBST library – both private and public – cannot be renamed.

Extras

The “*Extras*” sub menu contains some utility functions.

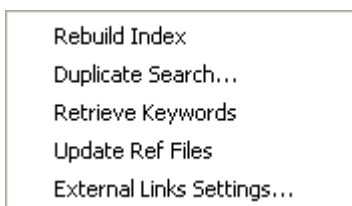

Rebuild Index

“*Rebuild Index*” recreates the LEAR indexes for a faster search. Normally the index is kept up to date automatically.

Duplicate Search

“*Duplicate Search*” allows to find duplicate entries.

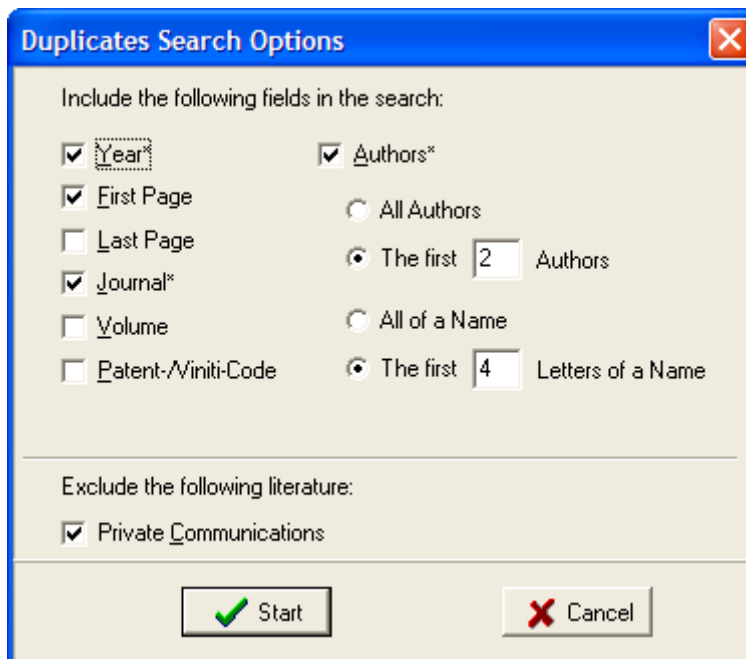

The “*Duplicate Search Options*” dialog allows to fine-tune the criteria.

The result of this search is a list with the duplicate entries which can be printed or copied.

Retrieve Keywords

“*Retrieve Keywords*”:
Currently the list of available keywords is stored in the user specific part of the registry. This functions adds all used keywords of the selected database to this list.

Update Ref Files

“*Update Ref Files*” exports all literature datasets of the selected library to *.ref files of the associated DDB folder. This function is only available for the DDBST and DDBST/p database. Only datasets with links will be exported.

External Links Settings

The external links facility allows to connect scans, data files, PDFs etc. pp. with a reference in the literature database. Use the “*External Links Settings*” dialog to configure the folders where the associated files reside.

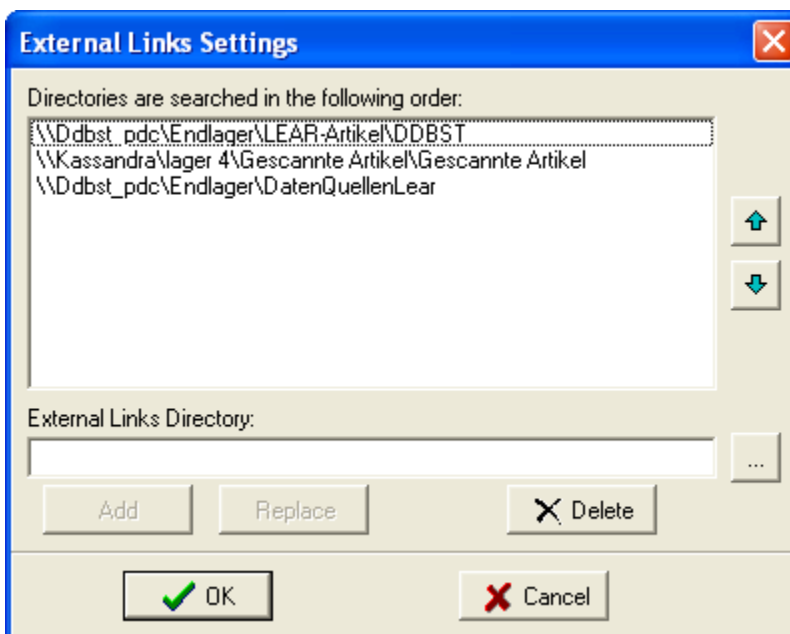

The folders can contain files of any type. The files must start with the associated literature dataset number. A leading “L” is as well allowed as leading zeros. Example: “1234.pdf”, “L1234.pdf”, “001234.pdf” and “L001234.pdf” will all refer to dataset number 1234.

The external link settings are database specific. The usage of external links is described in section *Displaying Externally Linked Files and Folders* on page 30.

Exit

“Exit” closes LEAR and all open result windows.

The Edit Menu



“Search...” opens the search dialog. Searching is described later in detail.

“Journals...” opens the journals list. This dialog is described later in detail.

“Options...” displays the “Global Options” dialog.

Global Options Page

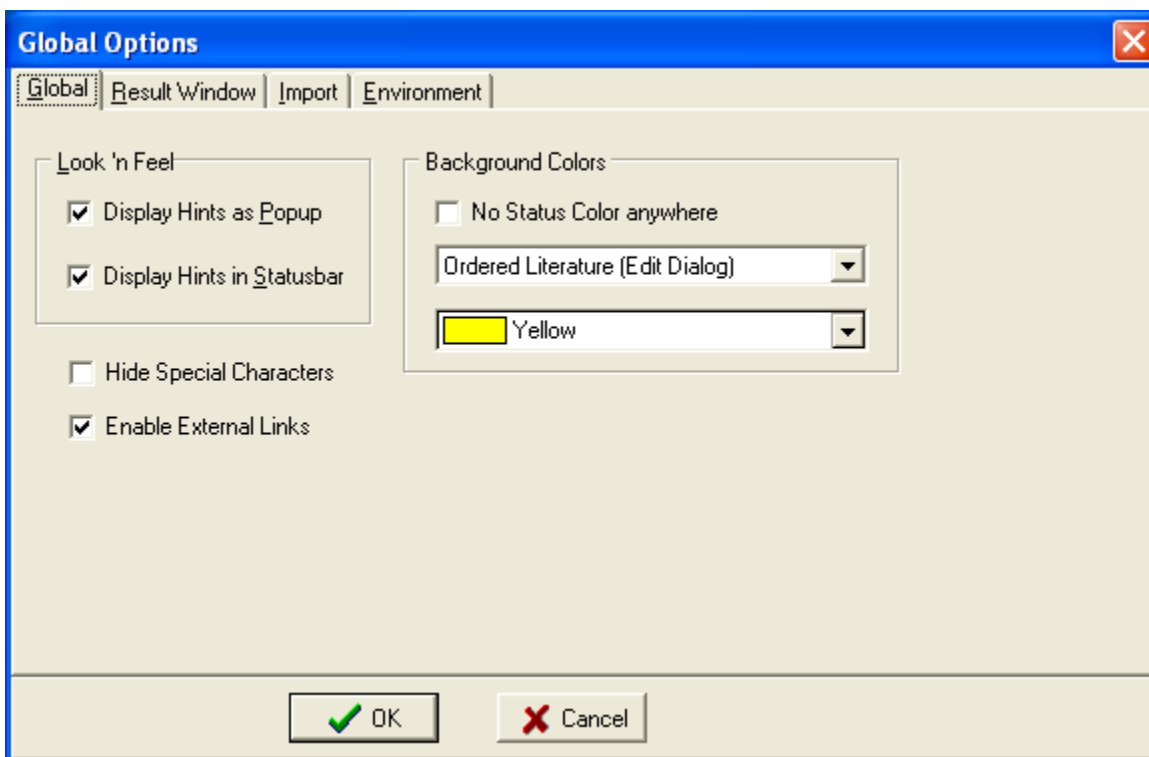

Hints are short descriptions of buttons. LEAR allows to display these short help strings either as small pop up windows at the mouse position or as strings in the status bar at the window bottom.

The color options are for displaying two special literature types.

- Ordered Literature (Edit Dialog)
- Ordered Literature (Result Dialog)
- Exhausted Literature (Edit Dialog)
- Exhausted Literature (Result Dialog)
- Transl. Available Literature (Edit Dialog)
- Transl. Available Literature (Result Dialog)

“Ordered Literature” are articles and books that are in the process of being procured, “Exhausted Literature” are articles and books that cannot be procured, mainly because they are too old (19th century for example). “Translation Available Literature” are articles which are available in another language. This applies mainly for Russian articles where an article translated to English is also stored.

The colors are used as background color either in the single dataset edit dialog or in the search result grid.

The “*Enable External Links*” box has to be checked to associate external files to a dataset.

Result Window Options Page

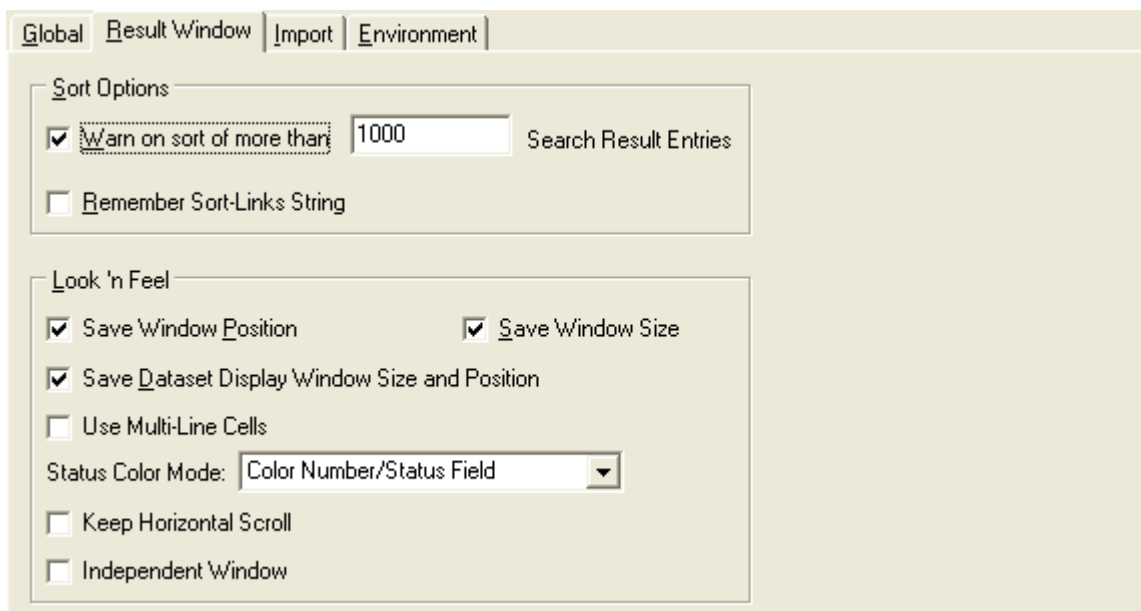

Since sorting of larger search results is rather slow and memory-consuming LEAR allows to display a warning if the search result is larger.

“Remember Sort-Links-String” describes the behavior of sorting a result grid by links.

The options “Save Window Position” and “Save Window Size” are related to the search result window whereas the “Save Dataset Display Window Size and Position” is related to the details window which can be opened in the search result.

With “Use Multi-Line Cells” turned on the cells in the result list expand vertically to fit to the text in the cells. Otherwise all cells have the same height. This is for example useful to see the complete title in the result list.

Multi-Line Cells turned off:

Number	Status	Title	Authors	Date
2	0 - avail...	Excess molar volumes and excess partial m...	Pal A.; Dass G.	19
3	0 - avail...	Partial molar volumes and their temperatur...	Parmar M.L.; Sharma S.	19

Multi-Line Cells turned on:

Number	Status	Title	Authors	Date
2	0 - available	Excess molar volumes and excess partial molar volumes of triethylene glycol monoethyl ether -n-alcohol mixtures at 25°C	Pal A.; Dass G.	19
3	0 - available	Partial molar volumes and their temperature derivatives for some transition metal nitrates in binary aqueous solutions of urea	Parmar M.L.; Sharma S.	19

Datasets which status indicates that the articles are currently not available can be marked with a special color in the result list. Use “Status Color” mode to modify the behavior.

With “Keep Horizontal Scroll” is turned on the result list does not jump to the first column when the keyboard is used to navigate through the list. The option can lead to some flickering effects.

Turn “Independent Window” on to have all result windows displayed in the Windows status bar. This option

will only take effect for windows opened after the option change.

Import Options Page

Since LEAR allows to import literature information from multiple sources it is a major task not to import duplicates.

The import options allow to fine-tune the search for duplicates.

Environment Options Page

The environment options are only displayed as an additional information.

The entries displayed here can be modified in the DDB configuration program.

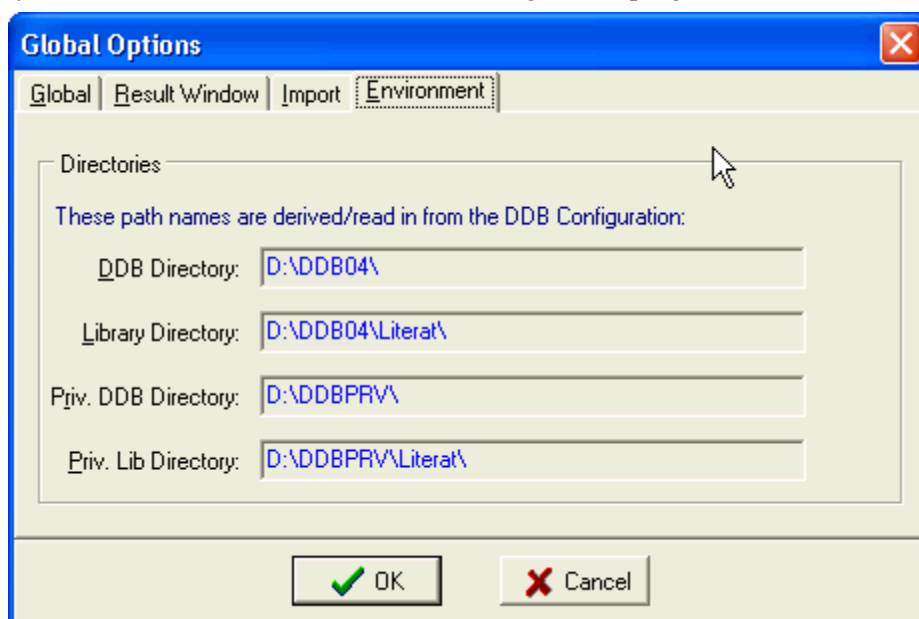

The View Menu

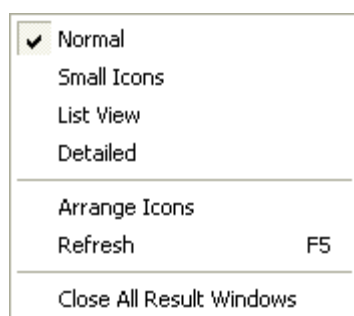

The entries "Normal, Small Icons", "List View", and "Detailed" change the display of the libraries.

Normal View:



Detailed View:

Literature Databases	Datasets	Last Edited	Location
DDBST	61427	Wed Apr 07 18:16:45 2004	D:\DDB0...
DDBST/p	1	Tue Apr 06 10:30:31 2004	D:\DDB...
My New Database/p	0	Mon May 17 09:27:10 2004	D:\DDB...

Figure 2 "Detailed"

“*Arrange Icons*” sorts the list of libraries and “*Refresh*” rebuilds the list.

“*Close All Result Windows*” closes all result windows.

The Help Menu

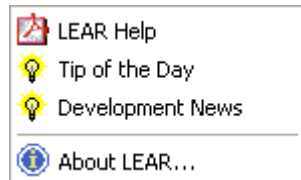

“*LEAR Help*” displays this paper.

“*Tip of the Day*” displays some useful hints for the work with LEAR.

“*Development News*” shows new tips for this version.

“*About LEAR*” displays detailed program version information.

Searching

The search can be started from the  button in the main window.



LEAR has implemented two search query modes – one simple and one complex. The simple search query is easier to handle but offers less options. It is possible to start with the simple query and copy the conditions to the complex query to refine the search conditions.

Quick Search

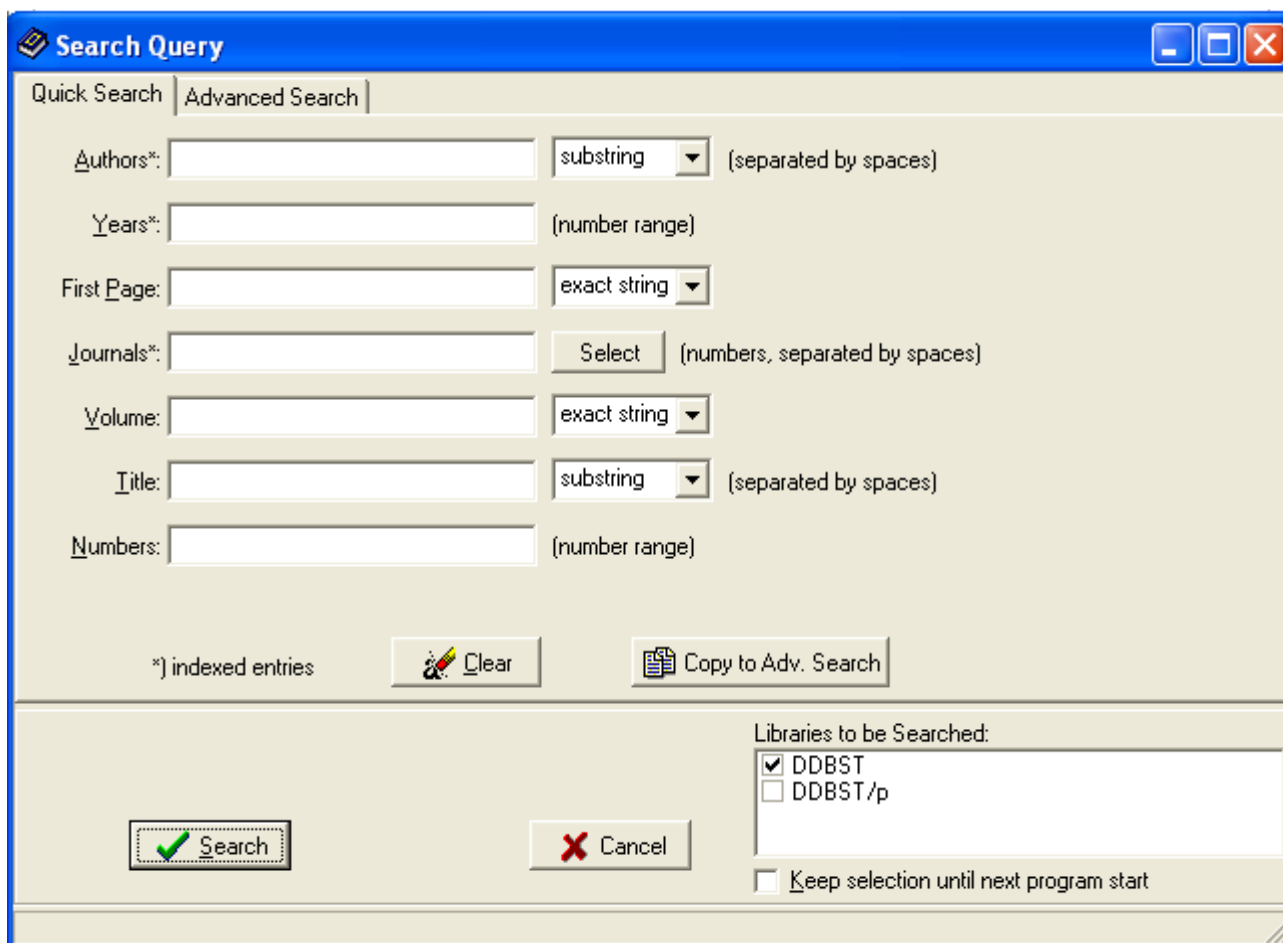

Available Fields are

- Authors** Several names can be entered. The single names have to be separated by spaces. Only references where all names are given will be found (“And” relation). It is possible to specify that the word(s) can match anywhere in the authors list (substring), can only match as full word (whole word). The other options are not very useful and only for completeness.
- Years** A single year or a range of years has to be entered. Any year must be specified with all four digits. A “/” can be used to define a continuous range, use “;” to separate single years. Example: To search for all literature published from 1980 to 1982 or in 1986 use “1980/1982;1986”.
- First Page** A single number has to be entered. Normally “exact match” is preferred, but it is also possible to allow a match as “prefix”, “suffix”, or “substring”.
- Journal** A list of numbers denoting the DDB journal numbers separated by blanks can be entered. Use the  button to select journals from the list. See below for details.
- Volume** Since volume can contain letters this search allows also a substring search. A search for “12” will also find “123” and “12A”. In addition all options as for “First Page” are possible.
- Title** Several words can be entered. The single words have to be separated by spaces. Only titles with all words available will be found (“And” relation). Use “whole word” to find full words only.
- Numbers** A range of dataset numbers can be specified (format as in “Years”). In most cases this field is not used in combination with the other options. Therefore the field is marked slightly yellow when the contents is not empty (to avoid unexpected search failures).

The “*” denotes the fields for which LEAR has indexes. These searches are much faster than non-indexed fields. The author index is no exact index.

 The “Clear” button will empty all edit fields. The additional options are not touched.

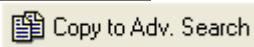
 The “Copy to Adv. Search” button copies the current quick search settings to the advanced search settings. The advanced search page is active afterwards.

The “Libraries to be Search” control contains all available literature databases. Only the selected databases are searched.

Advanced Search

The advanced search allows to search in almost all data fields (“Field” column). The “Mode” column contains options specific for the selected data fields. The “Operator” column allows (together the “String Mode” column) to change the behavior of the search. The “Words” columns contains the search text or number.

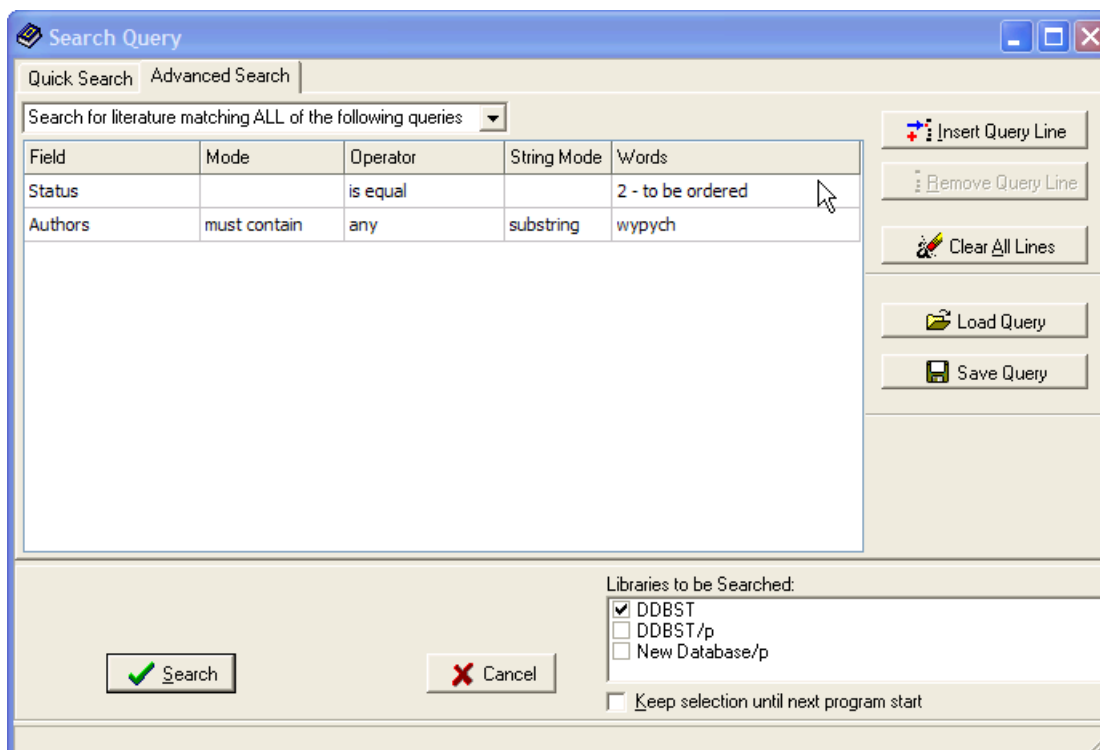

Search Fields

<u>A</u> uthors
<u>C</u> omment
F <u>ir</u> st Page
<u>J</u> ournal
<u>K</u> eywords
L <u>an</u> guage
L <u>as</u> t Page (0)
L <u>ea</u> r N <u>u</u> mer
<u>L</u> inks
L <u>oc</u> ation (1)
P <u>l</u> ace/Inst.
<u>S</u> tatus
<u>T</u> itle
<u>Y</u> ear
<u>U</u> ser defined Number
<u>V</u> olume
<u>I</u> ssue
R <u>e</u> port/Patent No.
F <u>ir</u> st Editor (2)
F <u>ir</u> st Edit Date (3)
L <u>as</u> t Edit Date (4)
L <u>as</u> t Editor (5)
S <u>e</u> ries (6)
B <u>o</u> ok Title (7)
S <u>e</u> ries Name (8)

String Fields

String Fields are “Authors”, “Comment”, “First Page”, “Keywords”, “Language”, “Last Page”, “Location”, “Place/Inst.”, “Title”, “User defined Number”, “Volume”, “Issue”, “Report/Patent No.”, “First Editor”, “Last Editor”, “Series”, “Book Title”, “Series Name”.

For *String Fields* the mode column has two options: “must contain” or “must not contain” and the operator column allows to search for “all” or “any” words in the words column. In addition it is possible to specify if a text must match as “substring”, “whole word”, “prefix”, “suffix” or “exact string”. The “Words” column accepts words separated by blanks. To search for text containing blanks enclose them in quotation marks.

Number Range Fields

Number Range Fields are “LEAR Number” and “Year”. It is possible to specify either one number and search for all which “is equal”, “is lower or equal” or “is greater or equal”. Or you can specify a number range (see quick search dialog for details).

Date Fields

Date Fields are “First Edit Date” and “Last Edit Date”. The “Words” column only accepts one valid date. Click on day, month, or year to change it. A click on the down arrow  brings up a date selection dialog. It is possible to search for dates which are “equal”, “lower or equal” or “greater or equal”.

Journal Field

It is possible to search for (“must contain”) or exclude (must not contain) datasets from a list of journals. Use the button  to view/edit the selected journals. See section *Selecting Journals* on page 24 for details.

Status

The status of an article can be “available”, “missing”, “to be ordered”, “urgent demand”, “in process”, “can't be procured”, “not ordered” or “check needed”. The word column presents a pop up menu with the possible entries.

Links

Links are simple numbers and data bank dependent (separate numbers for VLE, ACT, ...). The mode column contains the data banks list (from “aae” to “vle”) and the operator column allows to set the options “equal”, “lower or equal”, and “greater of equal”. The words column allows to enter a single number.

Multiple Queries

The advanced search dialog allows to enter multiple search queries.

Field	Mode	Operator	String Mode	Words
Year	of publication	is equal		2000
Authors	must contain	any	whole word	gmehling

 Insert Query Line adds a new line,



 Remove Query Line removes a line,

 Clear All Lines clears all query lines but leaves an empty initialized line (prepared for “Authors” search).

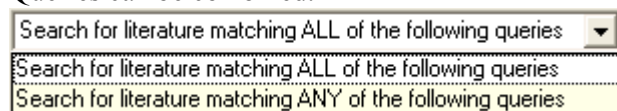
Queries can be combined.



- Either ALL query conditions must be fulfilled, or
- ANY (one) query condition must be fulfilled, other conditions can be fulfilled.

Use  Load Query to load and  Save Query to save a query. Queries are saved as INI files in a user specific folder.

 Search A click on the “Search” button will bring up the search result window (see next section). If nothing could be found the following dialog comes up:

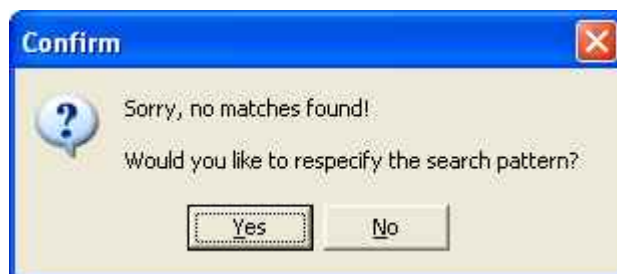

Click “Yes” to bring up the search query dialog again to refine the search option.

Search Results

After performing a search a query result window with all matches is displayed.

Number	Status	Title	Authors	Date	Pages	Volume	Journal
469	0 - available	Vapor-Liquid Equilibrium in the Binary System Hydrazine and Water	Wilson R.Q.; Munger H.P.; Clegg J.W.	1952	115 - 117	48	Chem.Eng.Prog.Symp.Ser.
5945	0 - available	The Physical Properties of Some Fluorine Compounds and Their Solutions. Part 2. - The System Sulphur Hexafluoride + Propane	Clegg H.P.; Rowlinson J.S.	1955	1333 - 1340	51	Trans.Faraday Soc.
6094	0 - available	Dehydration of Hydrazine by Azeotropic Distillation	Wilson R.Q.; Mink W.H.; Munger H.P.; Clegg J.W.	1955	220 - 224	1	AICHe J.
12228	0 - available	Thermodynamic Model of the System H+ - NH4+ - SO42- - NO3- - H2O at Tropospheric Temperatures	Clegg S.L.; Brimblecombe P.; Wexler A.S.	1998	2137 - 2145	102	J.Phys.Chem.A
17517	0 - available	The Henry's Law Constant of Trifluoroacetic Acid and its Partitioning into Liquid Water in the Atmosphere	Bowden D.J.; Clegg S.L.; Brimblecombe P.	1996	405 - 420	32	Chemosphere
18147	0 - available	Vapour Pressure of H2SO4/HNO3/HCl/HBr/H2O Solutions to Low Stratospheric Temperatures	Luo B.; Carlsaw K.S.; Peter T.; Clegg S.L.	1995	247 - 250	0	Geophys.Res.Lett.
18381	0 - available	Solubility of Ammonia in Pure Aqueous and Multicomponent Solutions	Clegg S.L.; Brimblecombe P.	1989	7237 - 7248	93	J.Phys.Chem.

Datasets: 45

Tool Bar



Close the search result window.



Close this and all other search result windows.



Copy marked sets to the Windows clipboard in a publication format.



Start email program (MAPI) with a new mail and the selected datasets as text file attachment (more than one entry selected) respective as text in mail body (one dataset selected). The default format is the publication format. To send the datasets in the display format click on the down arrow to get the

menu item.







Open a search query window. **A search started from this place will perform a search in the given **sublist**.** To search the full database either the full list must be active or switch back to the main window and start the search from there.

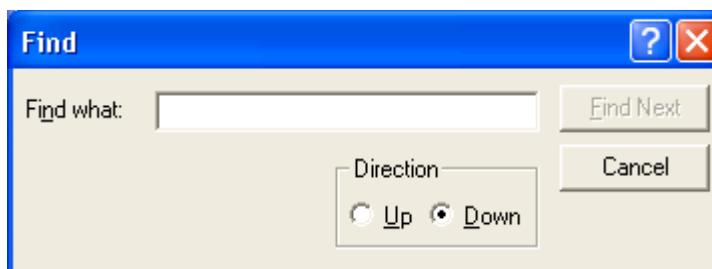

This search doesn't read the data bank but only the grid content.





The search result is not a new query result but the first grid line where the search item has been found will be selected.

-  Close the search result window.
-  Search for a data set number within this result list.
-  This function starts a search in the main data bank retrieval program for datasets of the marked references.
-  This function brings the main LEAR window to front.

Menus

Results









<ul style="list-style-type: none"> Export Export Selection Save Setnumbers.. Save Linknumbers... <hr/> <ul style="list-style-type: none">  Search for Data of Selection <hr/> <ul style="list-style-type: none">  Close Window 	<p>“<i>Export</i>” allows to save the grid content either as comma-separated files or as an Excel- and OpenOffice-compatible XLS files.</p> <p>“<i>Export Selection</i>” allows to export the marked datasets either as a tagged text file or as a LEAR library. If an existing LEAR library is selected, the marked sets will be appended.</p>	<div style="border: 1px solid black; padding: 5px; margin-bottom: 5px;"> <ul style="list-style-type: none"> ... as CSV ... as Excel Sheet <hr/> <ul style="list-style-type: none"> ... Extended as CSV </div> <div style="border: 1px solid black; padding: 5px;"> <ul style="list-style-type: none"> Tagged Format (ASCII) As LEAR library Structured XLS </div>
--	---	---

“*Save Setnumbers...*” allows to store the LEAR dataset numbers only. Private references are stored as negative numbers.

“*Save Linknumbers*” allows to store files containing link numbers. These link number are data bank specific ranges of data set numbers. LEAR asks for a folder where it will create several ““???”_links.stx” files where ““???” stands for a data bank short term (“vle”, “gle”, etc.).

See above for a description of “*Search for Data of Selection*” and “*Close Window*”.

Edit

<ul style="list-style-type: none"> Copy Selection  Email Selection <hr/> <ul style="list-style-type: none">  New Dataset Ctrl+N <hr/> <ul style="list-style-type: none">  Delete Selected Dataset(s) <hr/> <ul style="list-style-type: none"> Rename Result Window 	<p>“<i>Copy Selection</i>” allows to copy the marked lines either in a publication format for use in text processor or in a grid format for use in spread sheets.</p> <p>“<i>Email Selection</i>” allows to send the marked datasets either in publication or display format (see</p>	<div style="border: 1px solid black; padding: 5px; margin-bottom: 5px;"> <ul style="list-style-type: none">  Copy To Clipboard (Grid Contents)  Copy To Clipboard (Publication Format) Ctrl+C  Copy To Clipboard (Display Format) </div> <div style="border: 1px solid black; padding: 5px;"> <ul style="list-style-type: none">  Send Selected as Mail (Publication Format)  Send Selected as Mail (Display Format) </div>
---	---	--

above).

“New Dataset” opens the edit dialog and allows to enter a new dataset. This option is only available if the full list is active.

“*Delete Selected Datasets*” allows to remove datasets from the database. **This command actually deletes the datasets in the database. It is not recoverable.** Only references that are not used in the DDB can be removed.

Use “*Rename Result Window*” to give the result list a meaningful name. It is not possible to have two windows with the same name. Only the text between the brackets in the window title will change. Renaming the window

makes it easier to identify a specific search result when switching between them using the “*Windows*” menu entry or the task bar entries (“*Independent Window*” turned on)

Search

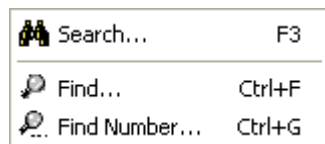

The search functions have been explained in the tool bar section.

View

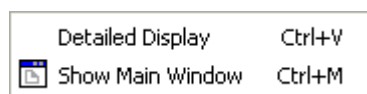

“*Detailed Display*” opens a child window with a detailed text view of the currently selected reference. The contents updates automatically when a different dataset is selected.

The text in the “*Dataset Display*” window can be printed and copied. It is possible to turn word wrap on an off and to set the window always on top.

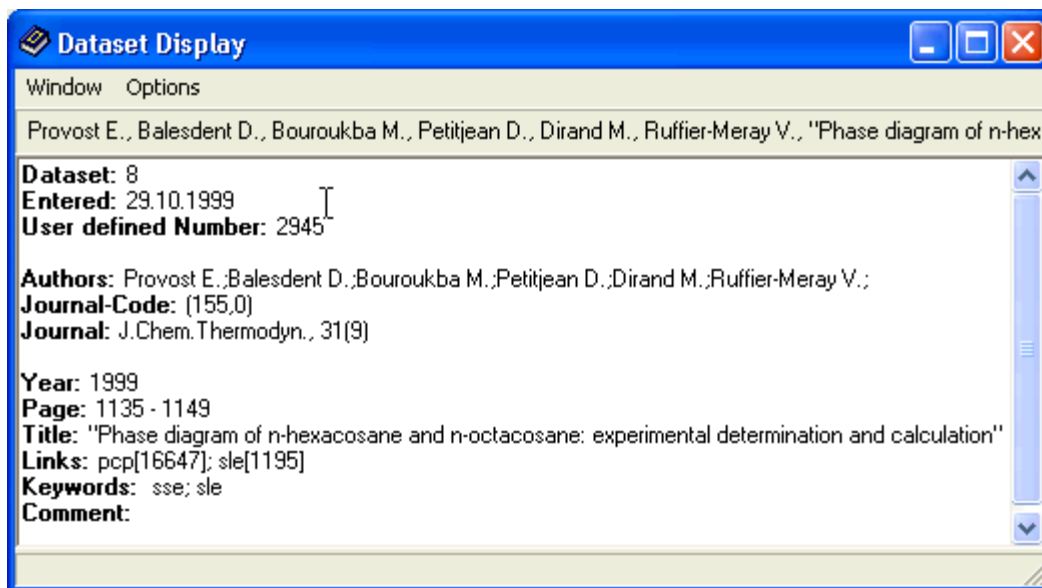

Options

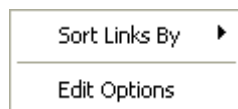

“*Sort Links By*” allows to select the sort mode if the datasets shall be sorted by the database links. Normal mode is simple sorting by alphabetical order. Since a reference might contain multiple links a reference with “*aae[34];vle[34]*” will be sorted by the “*aae*” entry. The “*vle*” link will not be used because it is on second place. This can be prohibited by choosing the “*vle*” link as basic sort criterion.

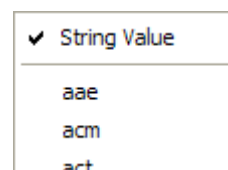

“*Edit Options*” displays the “*Result Window*” page of the global options dialog.

Windows

The “*Windows*” menu can be used to switch between several this is useful if “*Independent Window*” is turned off.

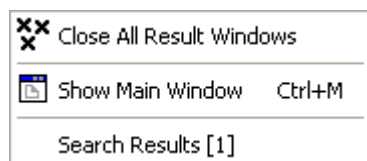

Grid Functions

Sorting

The grid allows to open an edit window for single set by double-clicking its line. Editing single sets is described in details elsewhere.

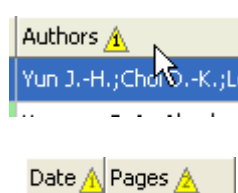

The grid allows to sort its content by clicking in the first row.

A second click on the same column reverts the sort order.

Shift-click allows to sort by more than one criterion, like sort first by date and second by pages.

Column Moving



It is possible to change the order of the columns. This is done by clicking on the heading of a column, holding down the left mouse button while moving the mouse cursor along the heading to the left or to the right.

Context Menu

The context menu of the grid repeats several of the functions of the tool bar and the menu. The following functions are unique.

Change Color of Column 'Title'...

“*Change Color of ...*” allows to select another background color for a column.

Hide Column 'Title'

A column can be removed from the result list. The only column that can't be removed is the “*Number*” column.

Insert Column

► Use “*Insert column*” to insert a hidden column into the result list. The column will be inserted *before* the column below the mouse cursor.

Remove Selection

“*Remove Selection*” allows to remove datasets from the search result list. This does *not* modify the database.

Create New Window from Selection

“*Create New Window from Selection*” opens a new search result window with only the selected sets.

Common Properties...

“*Common Properties*” opens an edit window which allows to edit common properties of the selected data sets.

Edit Common Properties

Pages: -

Date: - 1999

Journal: ...

Journal-CAS: ISSN:

Volume: Issue: Series:

Status: ▾

Location: User defined Number:

Language:

Keywords: ... ▾

Comment: ▾

These “common” properties have to be the same in all selected datasets before editing, the different entries are inactive and cannot be changed. The only exceptions are “Keywords” and “Comment”. If the entries are different it is possible to choose to “append” a value to all selected datasets or to “replace” the value in all selected datasets by the specified value. “None” will leave the entries unchanged. **The changes here modify the database.**

Journals

The journal's editor can be started from the “Edit” menu of LEAR's main window.

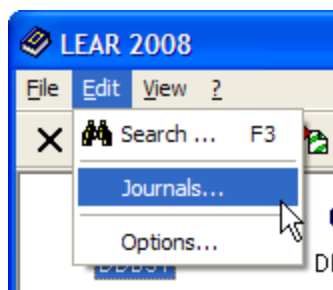

LEAR uses an underlying journals list and provides an editor for this list.

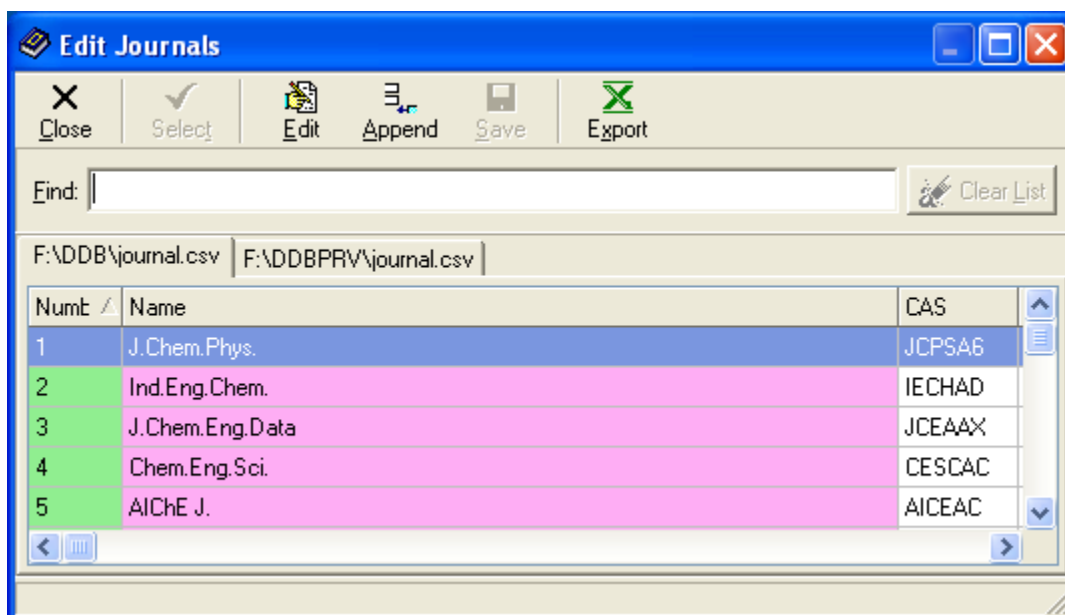

Stored Fields

The most important fields in the journals list are

- a journal number
- a journal short name
- the CAS source index
- the ISSN number
- a description of the type if the reference is not a journal.

Editing

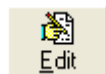

The single entries are editable after selecting the “Edit” button.

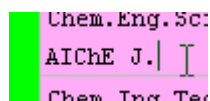

The “*Monography Type*” can be easily changed by choosing one item from the drop-down list. An empty field means “Journal”.

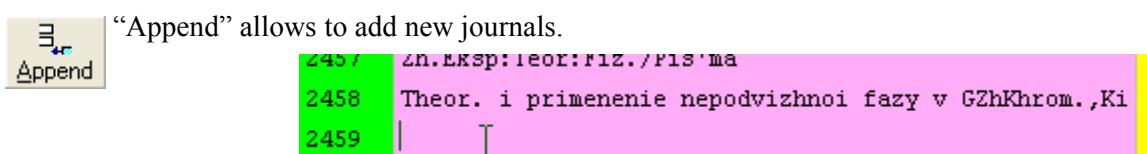
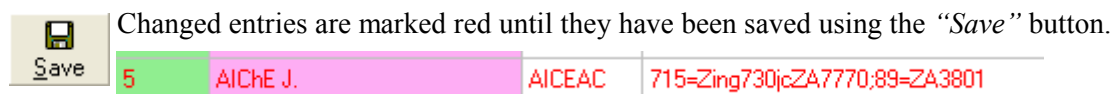

An empty row is appended to the journals grid and the grid is automatically in edit mode. By pressing the “*Save*” button the new journal can be used in the literature data bank.

Searching

Searching for journals allows to combine queries by simple logical operations.

Search String	Result
eng&chem	All journals containing “eng” and “chem” are listed.
eng chem	All journals containing either “eng” or “chem” are listed.
eng&chem&!trans	All journals containing “eng” and “chem” but not “trans” are listed.

Searching is always restricted to the currently listed journals. To search all journals the entire list can be made visible again by pressing the “Clear List” button.

Selecting Journals

The journals dialog is in selection mode when it is called from a search query window.

Field	Mode	Operator	String Mode	Words
Journal	must contain	any of the 2		Selected Journals

In this case the dialog hides the “*Edit*” and “*Append*” buttons and activates the “*Select*” button.



To select a single journal mark the grid line and press the “*Select*” button. It is also possible to select all marked journals by selecting one of the drop-down menu entries.

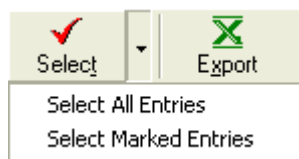

Editing Single Sets

The editor for single sets can be called by double-clicking a line in a search result or by adding new datasets from the main window.

The screenshot shows a software window titled "Edit Entry 5945 [DDBST]". The window contains a form with the following fields and values:

- Literature Kind: Article in Journal
- Dataset Number: 5945
- User defined Number: (empty)
- Title: The Physical Properties of Some Fluorine Compounds and Their Solutions. Part 2. - The System Sulphur Hexafluoride + Propane
- Authors: Clegg H.P., Rowlinson J.S.
- Pages: 1333 to 1340
- Volume: 51
- Issue: (empty)
- Series: (empty)
- Year: (empty) to 1955
- Journal: 47 Trans. Faraday Soc.
- Publ. Progr.: (empty)
- ISSN: 0014-7672
- Shelfmark: (empty)
- ZDB-ID: (empty)
- Publisher/Place: (empty)
- Language: (empty)
- Keywords: azd; cri; hpv; pcp;
- Entered at: (empty) By: (empty) Location: (empty) Status: available
- Comments: (empty)
- Links: azd[269]; hpv[804]; pcp[8657];

At the bottom of the window, there are two buttons: "Save" (with a green checkmark icon) and "Close" (with a red X icon).

List of Fields

The list of fields changes with the type of paper (monograph, article, etc.). In the following the most important fields are described.

- Literature Kind Defines the type of paper stored.

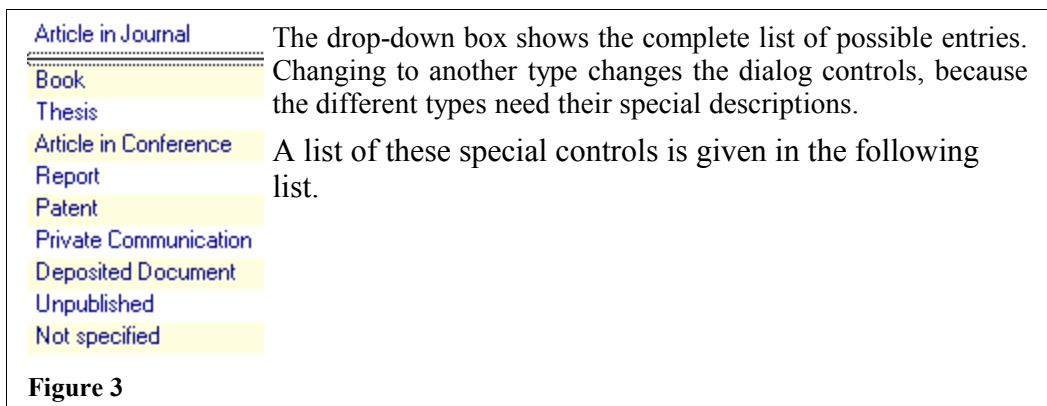

- Precise Kind



This list contains a list of a more precise description of the reference kind. This lists aren't complete and always contain an entry which can be used if nothing else matches (e. g. "monograph" for books).

- Dataset Number A unique number specifying the data set. This number is automatically created by the program and cannot be altered.
- User defined Number This is a freely definable number useful when another literature list has been imported in a LEAR library. It allows to keep the original numbering.
- Title The title of the paper.
- Authors The authors of the article. Each author has his or her own cell and the naming convention (for DDBST) data banks is family name followed by space and initials. The initials are not separated by blanks.

The order of the authors can be changed by dragging the title bar to a different location.

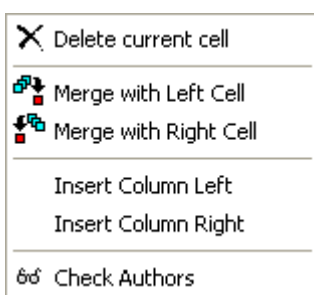

The context menu allows to delete a cell, merge two cells or insert a cell.

Press RETURN in the last cell to append a new cell.

The authors check function is also available (see below).

- Pages First page and last page of an article are stored in different fields. In case of an article from a book the first and last page should be used to denote the important pages.
- Year Normally articles have only one year whereas data collections may have been published over a period. If there's only one year given, this year should be entered in the 'to' field.

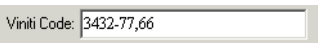
- Place A text field for further information on the authors, their institute or company.
- Viniti Code 

A “Viniti” is a specifically Russian and Ukrainian document type. It was and is common practice in the USSR and its successors that articles have been published only with their title and abstract. The rest of the paper with the experimental data are available from central libraries near Moscow and Kiev.
- Patent No. Patent number, only used for patents.
- Report Number Report number, only used for reports.
- Journal The journal list is a separate file. LEAR only stores a number which is an index to the journal in the journals file.

The journal can either be selected using the  button next to the journal name, by double-clicking in one of the grayed journal fields or by simply typing in the journal number left from the journal name. The journal selection dialog is described in section *Selecting Journals* on page 24.
- ISSN International standard series number of a journal. This field belongs to the journal entry and can only be modified in the journal editor.
- Volume Volume of an article
- Issue Issue number of an article
- Series Series number or letter of an article
- Book Title In article from a book “Title” contains the title of the article. “Book Title” can then contain the title for the whole book.
- ISBN International standard book number (for books only)
- Edition Edition of a book
- Editor Editor of a book
- Publisher / Place Name of the publisher (for book) or the place (for conference and thesis)
- Language The original language of the paper (Chinese, Japanese, German, etc.)

- Keywords LEAR manages keywords not as pure text, but as special list. This decision has been made for getting keywords organized.

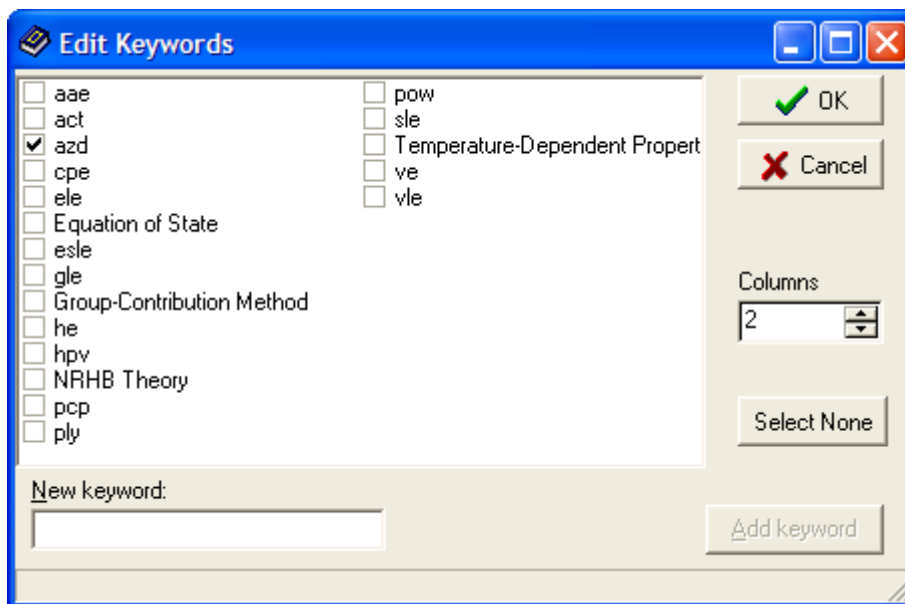

The list contains mostly short terms for the different DDB data banks.

- Entering Date Date of incorporation. This field is filled automatically and cannot be altered.
- Location A text field for defining the location of the paper.
- Status







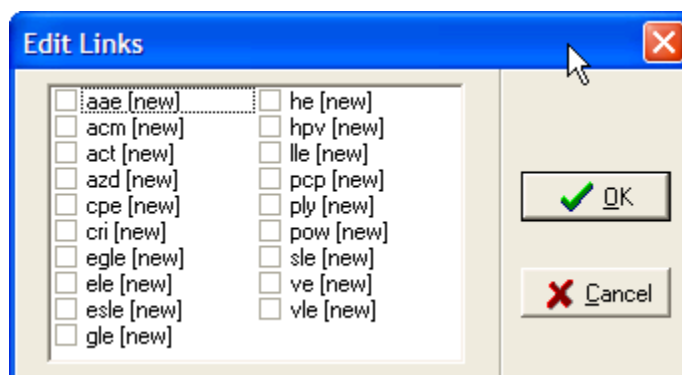

available
missing
to be ordered
urgent demand
in process
can't be procured
not ordered
check needed

 A short list of comments where the paper is currently in the working queue.

- Comments This a a place for unstructured additional information.
- Links Links are used to assigning an article to a data bank.



Tool Bar

-  Close the edit dialog
-  Copy dialog content to the clipboard (tagged format)
-  Paste dialog content from the clipboard (tagged format)
-  Copy dialog content to the Windows clipboard – either in publication format or in display format
-  Print dialog content
-  Start main data bank retrieval program and display all datasets from current reference.
-  Show external links (see below for details)
-  Font selection (see below)

Special Command Buttons

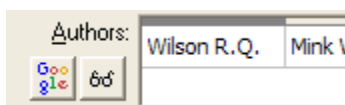

The eyeglasses button besides the authors allows to check the authors names order. The Google button  starts a search in the registered web browser by submitting a search URL like “<http://www.google.com/search?q=Wilson%20R.Q.%20Mink%20W.H.%20Clegg%20J.W.>”

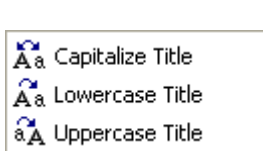
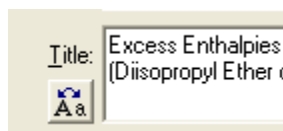

The  button calls a simple function for converting the title in uppercase/lowercase text. This function is far from perfect.

Right-click on the button to get a menu which allows also to convert all to uppercase or all to lowercase.

Font Selection

The single set editor allows to change the font of the dialog's controls.

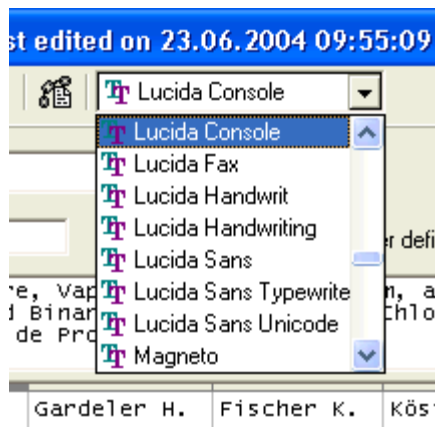

Here's an example where the font is changed from Lucida Console

Horstmann S.	Gardeler H.	Fischer K.	Köster F.	Gmehling J.
--------------	-------------	------------	-----------	-------------

to Arial.

Horstmann S.	Gardeler H.	Fischer K.	Köster F.	Gmehling J.
--------------	-------------	------------	-----------	-------------

Displaying Externally Linked Files and Folders

The external links facility allows to connect scans, data files, PDFs etc. with a reference in the literature database. The dialog which displays the linked files and folders can be directly displayed from within the single dataset editor. If the connection symbol  is enabled there are files associated with the current dataset.

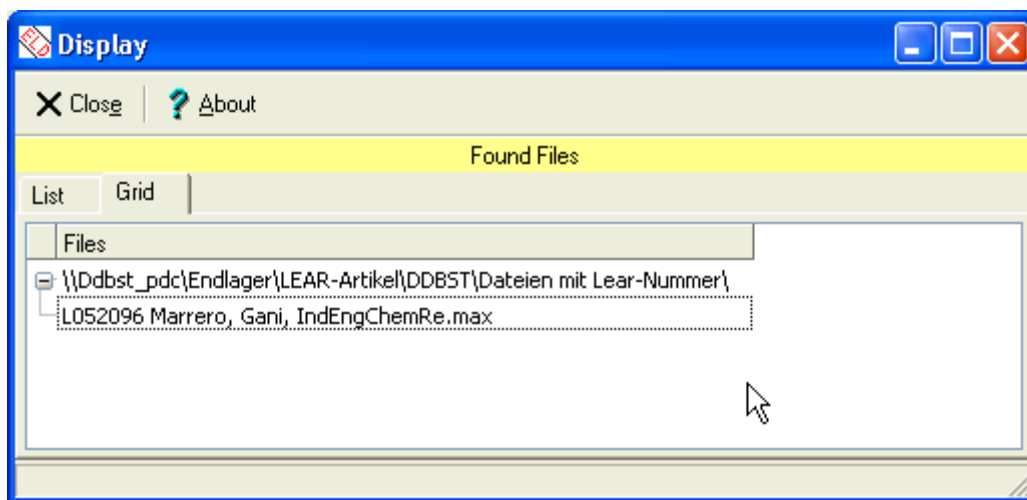
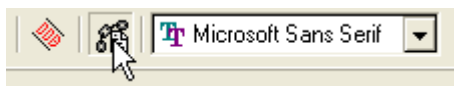

The link display dialog displays the linked files and folders. Double-click on a filename to load the document into the registered application. Double-click on a folder name to see the full folder contents.

Section *External Links Settings* on page 7 describes how to configure the folders for external files.

Appendix

The Usage of Links

The motivation for creating the Dortmund Data Bank was to have experimental data for fitting parameters for correlation and prediction models. This led to the conclusion that only originally published values are useful to have in the data bank and that led to the conclusion that the data sets have to be referenced.

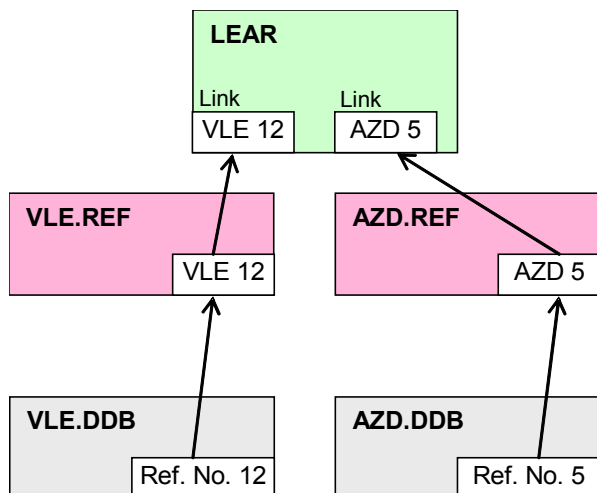

In earlier days these references have been stored in separate lists for every data bank. This caused problems in adding references (multiple copies of a single paper had to be stored if a single paper contained data for different data banks) and searching (several files had to be searched).

To overcome these problems a new and unified literature management has been introduced called LEAR (Literature Excerpt, Archiving, Retrieval). All single reference lists are still existent because the data banks still have their own numbering system (ranging from one up to their respective highest available number) but the references are now in one list and the old numbers are included in this list (see Figure 1).

The new management makes it easier to find references, no duplicates are introduced anymore and there's only a single place for editing and adding reference information.

The Data Bank Structure

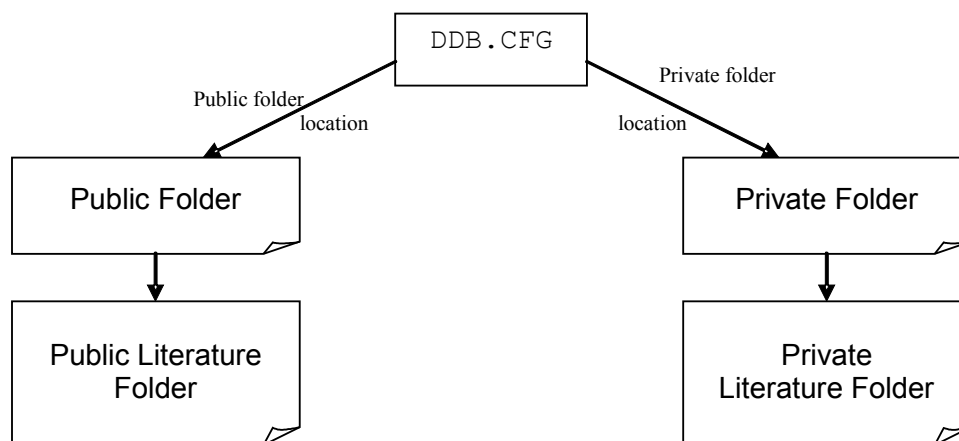

LEAR has been designed to support multiple libraries, two of these libraries have special meanings. The DDB

system supports two data banks, a public and private data bank. These are normally located in two different folders. LEAR uses this organization and supports a private and a public literature data bank.

A private data bank is intended for use by our customers to store company owned data and literature. The public data bank is distributed by DDBST GmbH.

LEAR tagged format

The tagged format (ASCII) is used for example when a single dataset is copied to the clipboard. The defined tags are:

<i>Tag</i>	<i>Meaning</i>
SET:	Data set number
CLA:	List of links in the format DDB-short-term (HE for mixing enthalpies in the example) followed by the link number in square brackets. If there are more links each are separated by blanks.
AUT:	Authors
TIT:	Title
DCL:	Journal class
JRC:	Journal number (from the DDB journals list)
JRN:	Journal short name
JCS:	Journal code (CAS source index)
JLT:	Journal long name
LNG:	Language
PNR:	Patent number
YEA:	Year
PGE:	First and last page separated by blank
VOL:	Volume
SER:	Series
ISS:	Issue
PLC:	Place
BTI:	Book title
EDI:	Edition
ISB:	ISBN
SNA:	Series name
ENA:	Editor name
CMT:	Comment
UDN:	User defined number
KWD:	Keywords
EDA:	First edit date

<i>Tag</i>	<i>Meaning</i>
CRE:	First editor
LOC:	Internal location
STA:	Status
LDA:	Last edit date
LED:	Last editor